

Standard Construction and Materials

FRAME: .063" thk. (nominal) extruded aluminum, 6063-T52/T6 alloy.

BLADE: .063" thk. (nominal) extruded aluminum, 6063-T52/T6 alloy.
Blades approximately 1½" on center.

LOUVER FACE: All surfaces are flush, with jambs contained within head and sill.

SCREEN: (When indicated.)

½" flattened aluminum (.051" thick),

-or- ½" sq. mesh, intermediate double-crimped aluminum wire, .063" dia.,

-or- 19/16 mesh, .011" dia. aluminum wire, insect screen.

FINISH: Mill

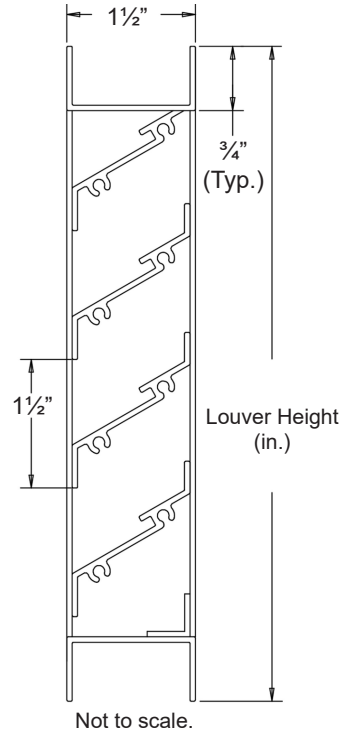

Options

Finish - Baked Enamel, Kynar, Anodize

Notes

- Nominal deductions will be made to the opening size given.
- Approximate shipping weight is 3.8 lbs./sq.ft.

Louver Sizes

Min Panel	Max Single Panel
12"W x 12"H	60"W x 96"H

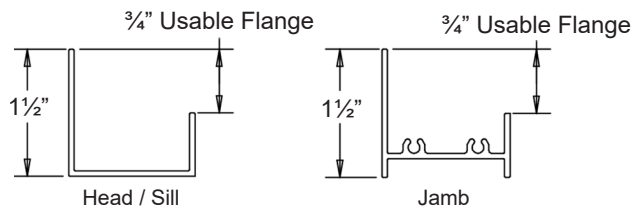

Flange Frame Option

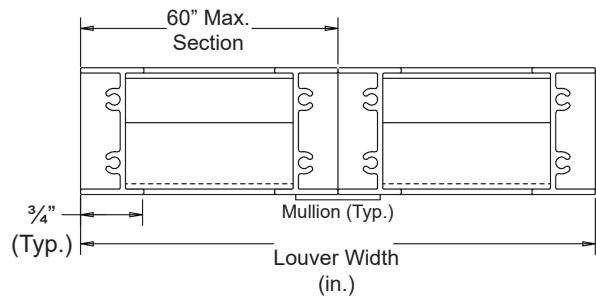

										
Item #	Qty	Width	Height	Width	Height	Mullion	Type	Location		
		Opening Size		Louver Size			Screens			Union Made
Arch. / Eng.:						EDR:		ECN:		Job:
Contractor:										
Project:						Date:		DWN:		DWG:

In the interest of product development, Cesco Products reserves the right to make changes without notice.



450 Riverside Dr • Wyalusing PA, 18853
Phone: 570-746-1888 • Fax: 570-746-9286
www.cescoproducts.com

Performance Data

Pressure Drop: .034 in. w.g. at 495 fpm (Intake)

Free Area: 7.37 sq.ft. = 46.06% for 48"W x 48"H sample tested in accordance with AMCA Standard 500-L.

Beginning Point of Water Penetration: 459 fpm

Ratings do not include effects of a screen.

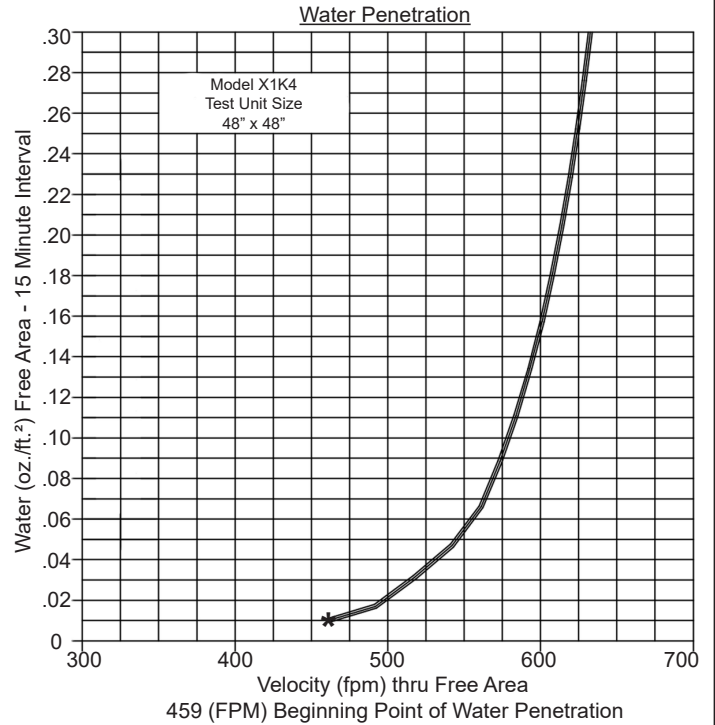
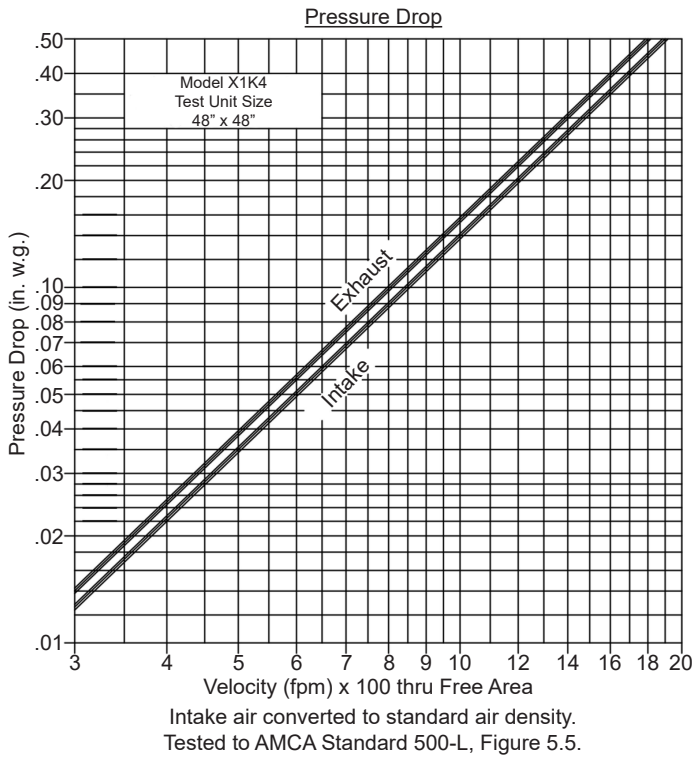

Free Area (sq.ft.)

		Width (in.)								
		12"	18"	24"	30"	36"	42"	48"	54"	60"
Height (in.)	12"	.33	.52	.71	.90	1.09	1.28	1.47	1.66	1.85
	24"	.78	1.22	1.66	2.11	2.55	2.99	3.44	3.88	4.32
	36"	1.22	1.92	2.61	3.31	4.01	4.70	5.40	6.10	6.80
	48"	1.66	2.61	3.56	4.52	5.47	6.42	7.37	8.32	9.27
	60"	2.11	3.31	4.52	5.72	6.92	8.13	9.33	10.54	11.74
	72"	2.55	4.01	5.47	6.93	8.38	9.84	11.30	12.76	14.22
	84"	3.00	4.71	6.42	8.13	9.84	11.55	13.27	14.98	16.69
	96"	3.44	5.40	7.37	9.34	11.30	13.27	15.23	17.20	19.16

AMCA registered laboratory is a laboratory equipped and staffed to conduct tests according to the appropriate AMCA test methods and which has been licensed as an AMCA registered laboratory.